



We're Satisfied with Your Satisfaction.



CHANGZHOU A-ZEN TEXTILE TECHNOLOGY CO.,LTD

E-mail: info@azentex.com

Website: www.azentex.com



Double Needle Bar Machine

双针床系列经编机

AZ2885

RD5

RD6

RD7

RDJ5/1

RDJ6/1

RDJ6/2

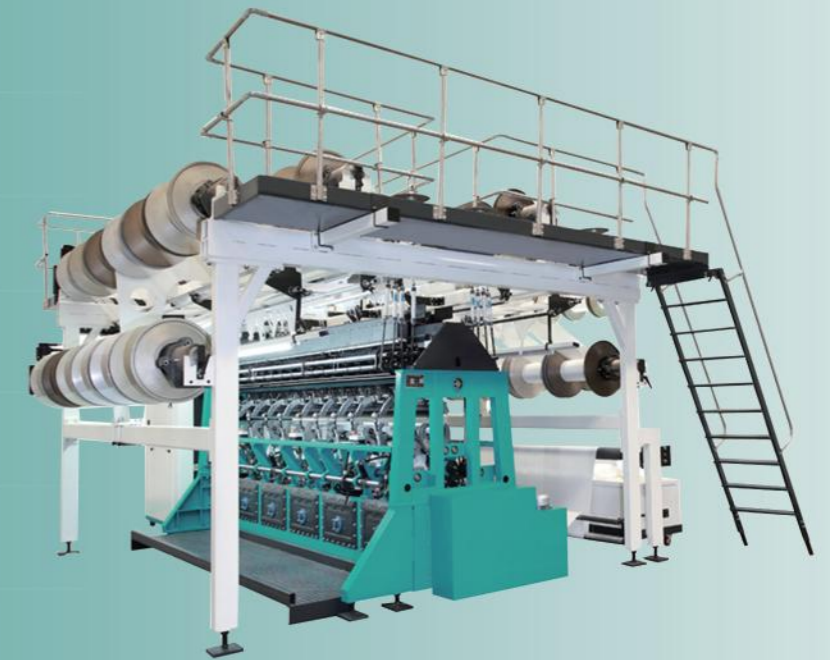

AZ2885 Raschel Blanket Machine

AZ2885型拉舍尔毛毯经编机



AZ2885是一款专门生产高品质毛毯、地毯、毛巾布等毛绒类织物的高性能经编机。

AZ2885 is a high-performance warp knitting machine specialized in producing high-quality blankets, carpets, terry cloth and other plush fabrics.

机器特点

1. 不同工作幅宽可选, 满足不同产品需求;
2. 开档范围可调节, 最大开档可达300mm;
3. 最高工作转速可达850转/分钟, 生产产能显著提升;
4. 机台使用可靠的机械以及电气配件, 生产效率稳定。

Products Features

1. Different working widths are available to meet different product needs;
2. The knock-over range is adjustable, and the maximum distance can reach 300mm;
3. The maximum working speed can reach 850 rpm, significantly improving production capacity;
4. The machine uses reliable mechanical and electrical accessories to ensure stable production efficiency.

技术参数

工作门幅/机号

- 110" E18/22
- 145" E18/22
- 170" E18/22
- 190" E18/22

Working Width/Gauge

- 110" E18/22
- 145" E18/22
- 170" E18/22
- 190" E18/22

梳栉数

5把地梳

Bars Number

5 Ground Bars

脱圈板间距

8-24mm (中短绒);
12-50mm (中长绒)

Knock-over Distance

8-24mm (Short-Middle Pile);
12-50mm (Middle-Long Pile)

舌针类型

针块式舌针

Latch Needle Spec.

Latch Needle Block

横移方式

花盘横移, 或仅GB3使用EL横移

Pattern Drive

Pattern Disc, or GB3 uses EL Drive

卷取方式

机械卷取, 或电子卷取

Batching Device

Mechanical, or Electrical Batching

送经方式

EBA, 或EBC送经

Yarn Let-off

EBA, or EBC

盘头配置

GB1, GB2, GB4, GB5使用Φ21" 或Φ30",
GB3使用Φ30" 或Φ40"

Beam Size

GB1, GB2, GB4, GB5 use Φ21" or Φ30",
GB3 uses Φ30" or Φ40"



Scan the QR code

应用图片 Applications

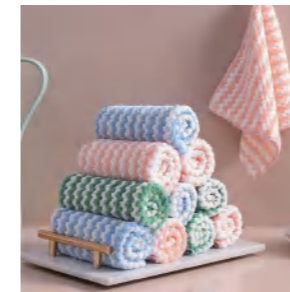

超细纤维毛巾布
microfiber cleaning rag



大兔毛
faux fur

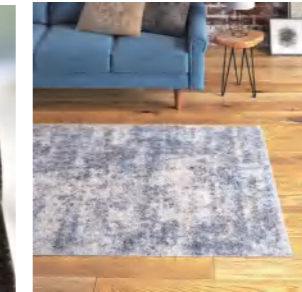

地毯
carpet



毛毯
blanket

机器照片 Machine photos



安装示意图 Installation diagram

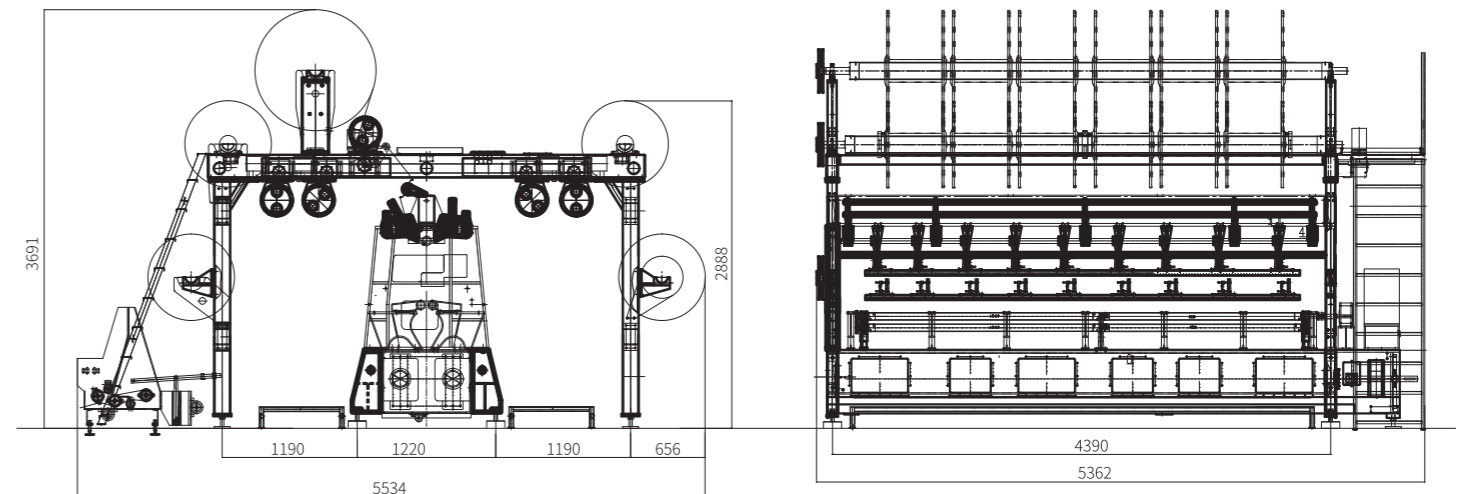

RD5是一款专门生产高品质毛绒类或间隔织物的高性能经编机。
RD5 is a high-performance warp knitting machine specialized in producing high-quality plush or spacer fabrics.

机器特点

1. 可生产更细腻的高品质毛绒织物；
2. 选用嵌入式舌针，降低维护成本，提高生产效率；
3. 配备电子横移和电子送经系统，机器性能更加卓越。

Products Features

1. Can produce more delicate and high-quality plush fabrics;
2. Use individual latch needle to reduce maintenance costs and improve production efficiency;
3. Equipped with electronic take-off and EL drive systems, the machine performance is even more excellent.

技术参数

工作门幅/机号

138" E18/22
170" E18/22

Working Width/Gauge

138" E18/22
170" E18/22

梳栉数

5把地梳

Bars Number

5 Ground Bars

脱圈板间距

2-12mm

Knock-over Distance

2-12mm

舌针类型

针块式舌针，或嵌入式舌针

Latch Needle Spec.

Latch Needle Block, or Individual Latch Needle

横移方式

花盘横移，或电子横移

Pattern Drive

Pattern Disc, or EL Drive

卷取方式

机械卷取，或电子卷取

Batching Device

Mechanical, or Electrical Batching

送经方式

EBA, 或EBC送经

Yarn Let-off

EBA, or EBC

盘头配置

GB1, GB2, GB4, GB5使用Φ21" 或Φ30" ,
GB3使用Φ30" 或Φ40"

Beam Size

GB1, GB2, GB4, GB5 use Φ21" or Φ30" , GB3 uses Φ30" or Φ40"



应用图片 Applications



3D Mattress



3D Mattress



spacer backpack

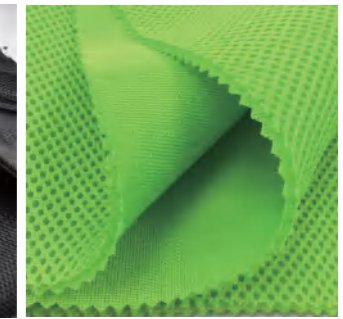

spacer backpack

机器照片 Machine photos

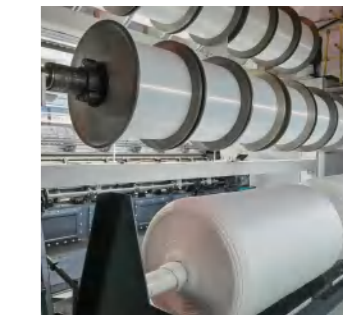

安装示意图 Installation diagram

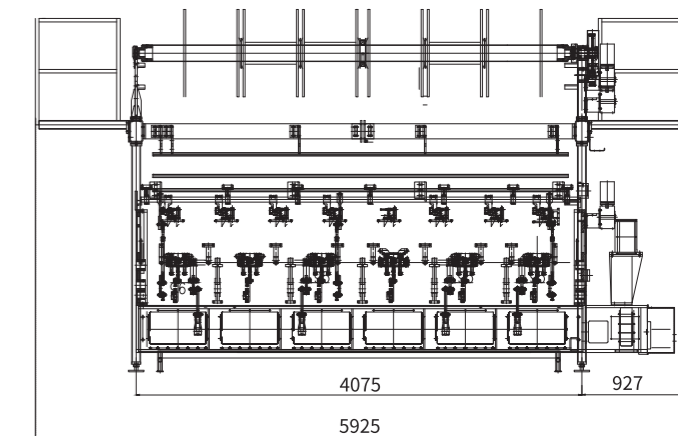
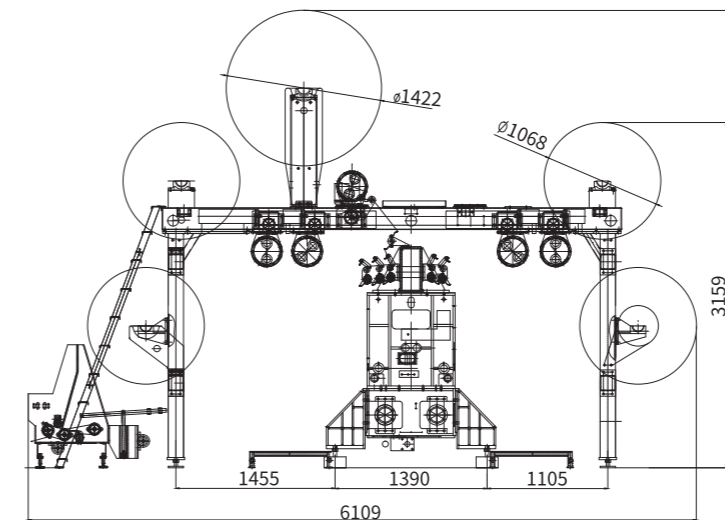

RD6是一款专门生产高品质毛绒类或间隔织物的高性能经编机。

RD6 is a high-performance warp knitting machine specialized in producing high-quality plush or spacer fabrics.

机器特点

1. 可生产更细腻的高品质毛绒织物和三明治织物;
2. 选用嵌入式舌针, 降低维护成本, 提高生产效率;
3. 配备电子横移和电子送经系统, 机器性能更加卓越。

Products Features

1. Can produce more delicate and high-quality plush and spacer fabrics;
2. Use individual latch and needle to reduce maintenance costs and improve production efficiency;
3. Equipped with electronic take-off and EL drive systems, the machine performance is even more excellent.

技术参数

工作门幅/机号

138" E22/24

170" E22/24

Working Width/Gauge

138" E22/24

170" E22/24

梳栉数

6把地梳

Bars Number

6 Ground Bars

脱圈板间距

2-12mm

Knock-over Distance

2-12mm

舌针类型

针块式舌针, 或嵌入式舌针

Latch Needle Spec.

Latch Needle Block, or Individual Latch Needle

横移方式

花盘横移, 或电子横移

Pattern Drive

Pattern Disc, or EL Drive

卷取方式

电子卷取

Batching Device

Electrical Batching

送经方式

EBC送经

Yarn Let-off

EBC

盘头配置

所有梳栉均使用Φ21" 或Φ30"

Beam Size

All Bars use Φ21" or Φ30"



Scan the QR code

应用图片 Applications

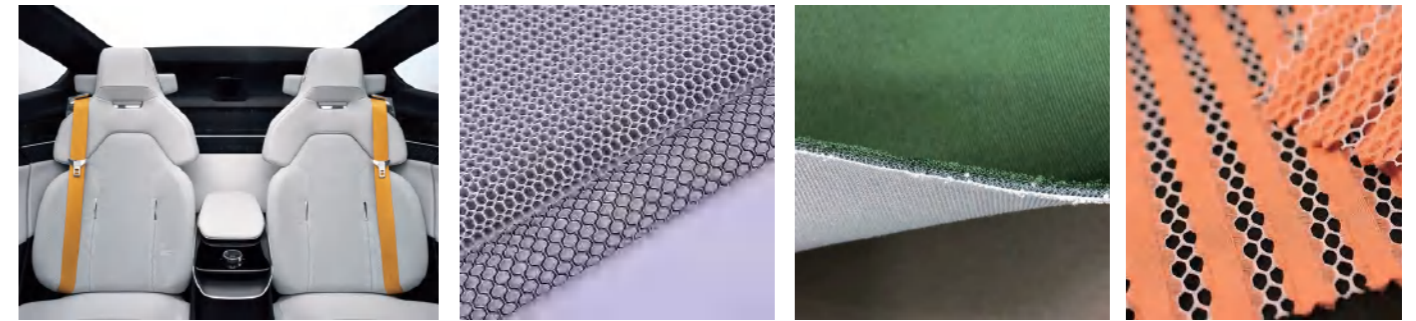

机器照片 Machine photos

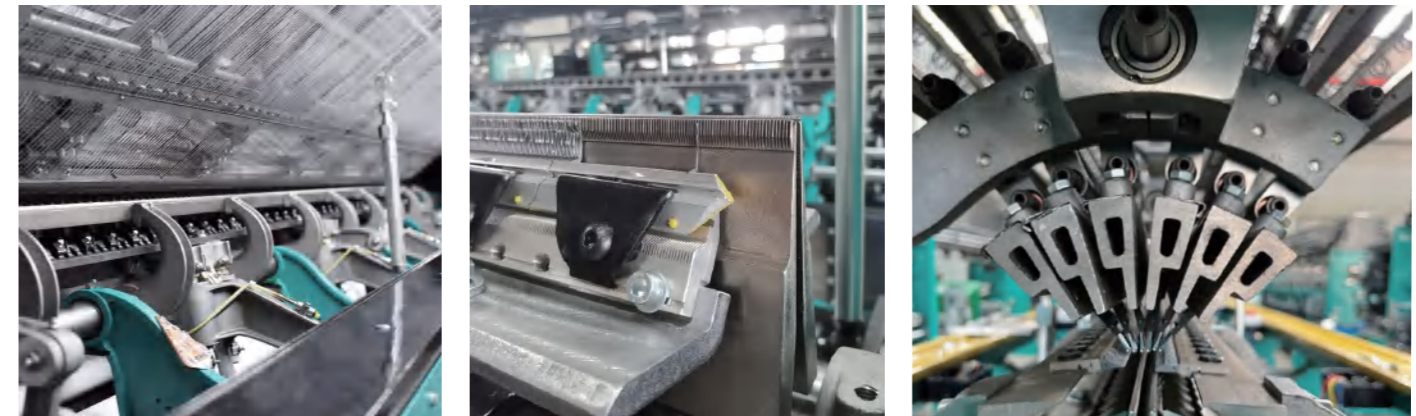

安装示意图 Installation diagram

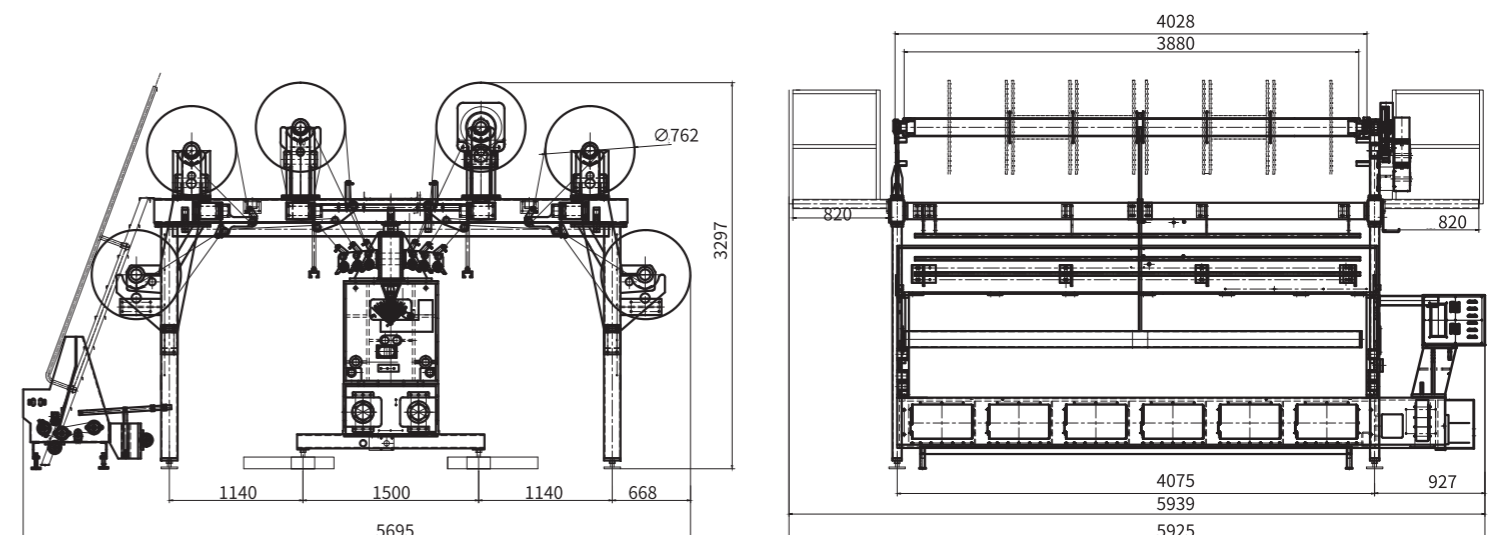

RD7是一款专门生产空气间隔织物的高性能经编机。
RD7 is a high-performance warp knitting machine specialized in producing high-quality air spacer fabrics.

机器特点

1. 可生产花型更加丰富的间隔织物;
2. 选用嵌入式舌针, 降低维护成本, 提高生产效率;
3. 配备电子横移和电子送经系统, 机器性能更加卓越;
4. 人机操作界面友好, 机器使用更加便捷。

Products Features

1. Can produce spacer fabrics with richer patterns;
2. Use individual latch needle to reduce maintenance costs and improve production efficiency;
3. Equipped with EL and EBC let-off systems, the machine performance is even more excellent;
4. The human-machine operation interface is friendly and the machine is more convenient to use.

技术参数

工作门幅/机号

138" E22/24
170" E22/24

Working Width/Gauge

138" E22/24
170" E22/24

梳栉数

7把地梳

Bars Number

7 Ground Bars

脱圈板间距

2-12mm

Knock-over Distance

2-12mm

舌针类型

嵌入式舌针

Latch Needle Spec.

Individual Latch Needle

横移方式

电子横移

Pattern Drive

EL Drive

卷取方式

电子卷取

Batching Device

Electrical Batching

送经方式

EBC送经

Yarn Let-off

EBC

盘头配置

所有梳栉均使用Φ21" 或Φ30"

Beam Size

All Bars use Φ21" or Φ30"



Scan the QR code

应用图片 Applications

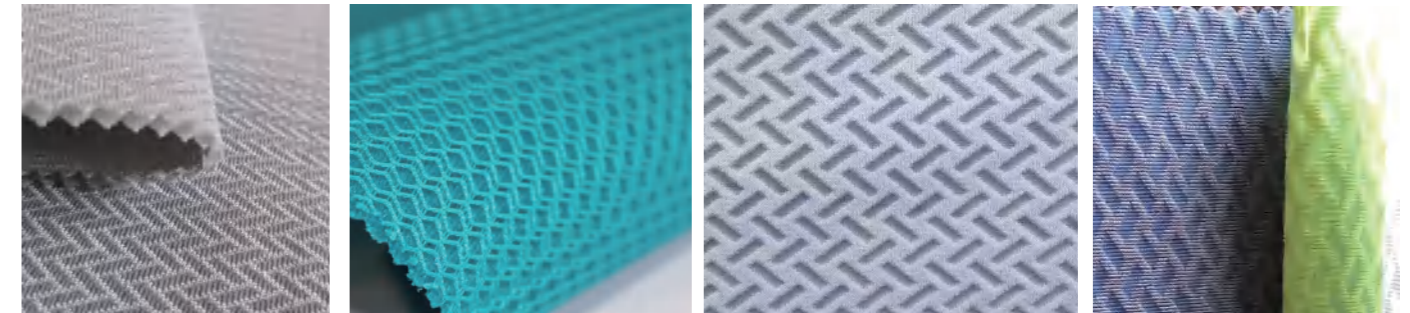

机器照片 Machine photos



安装示意图 Installation diagram

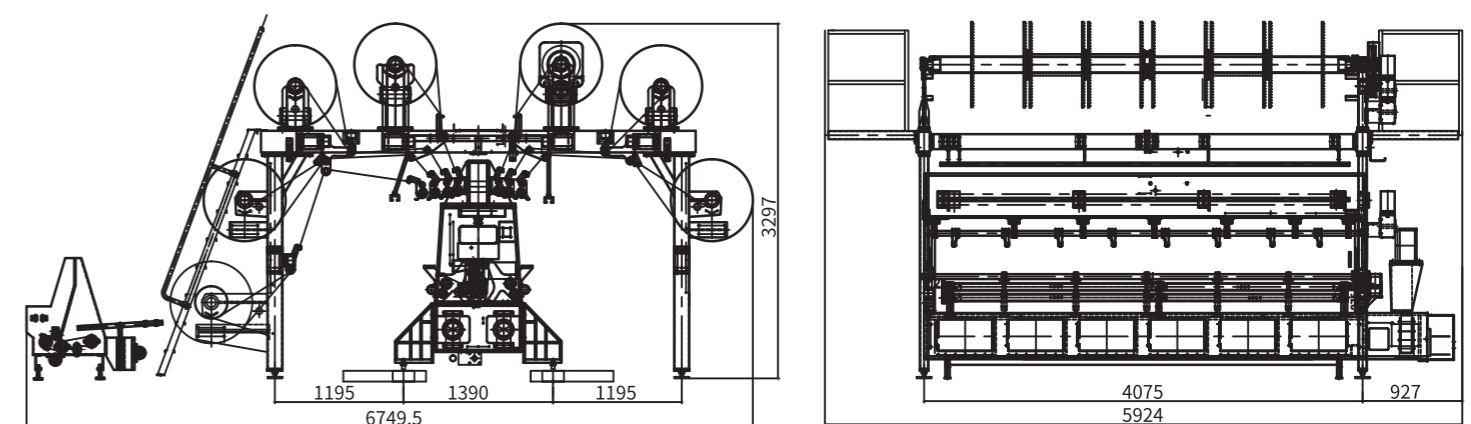

RDJ5/1是一款专门提花间隔织物的高性能经编机,其织物广泛应用于鞋面、床垫以及外衣等领域。

RDJ5/1 is a high-performance warp knitting machine specializing in jacquard spacer fabrics. Its fabrics are widely used in shoe uppers, mattresses, outerwear and other fields.

机器特点

1. 提花能力强大,应用领域广泛;
2. 选用嵌入式舌针,降低维护成本,提高生产效率;
3. 配备电子横移和电子送经系统,机器性能更加卓越;
4. 人机操作界面友好,机器使用更加便捷。

Products Features

1. Strong jacquard ability and wide application fields;
2. Use individual latch needle to reduce maintenance costs and improve production efficiency;
3. Equipped with EL and electronic let-off systems, the machine performance is even more excellent;
4. The human-machine operation interface is friendly and the machine is more convenient to use.

技术参数

工作门幅/机号

138" E22/24

梳栉数

4把地梳,
1把分离式贾卡梳

脱圈板间距

2-8mm

舌针类型

嵌入式舌针

横移方式

电子横移

卷取方式

电子卷取

送经方式

EBC送经

盘头配置

所有梳栉均使用Φ21“或Φ30“

Working Width/Gauge

138" E22/24

Bars Number

4 Ground Bars,
and 1 separate piezo jacquard bar.

Knock-over Distance

2-8mm

Latch Needle Spec.

Individual Latch Needle

Pattern Drive

EL Drive

Batching Device

Electrical Batching

Yarn Let-off

EBC

Beam Size

All Bars use Φ21“ or Φ30“



Scan the QR code

应用图片 Applications



Jacquard Spacer Fabric



Jacquard Spacer Fabrics



Mattress Spacer



Sports Shoe

梳栉排布图 Bars Arrangement

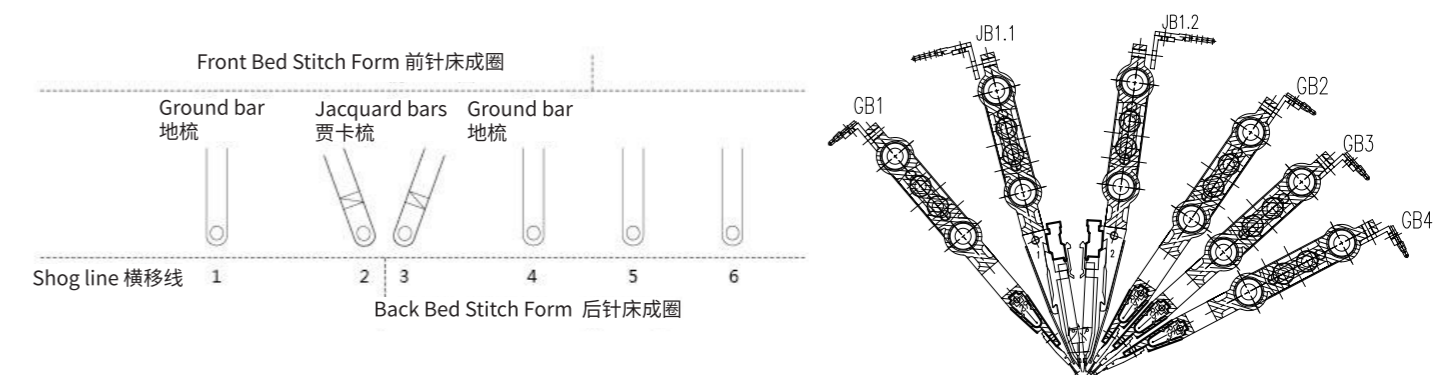

安装示意图 Installation diagram

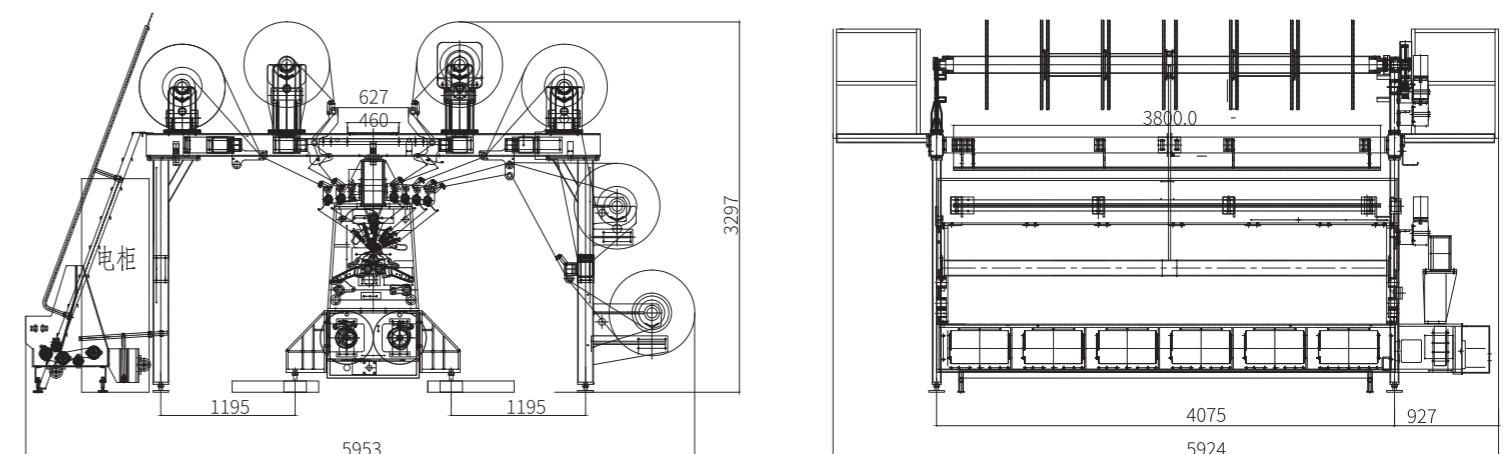

RDJ6/1(RDJ7/1)是一款专门提花鞋面织物的高性能经编机。
RDJ6/1(RDJ7/1) is a high-performance warp knitting machine specializing in jacquard spacer shoe uppers fabrics.

机器特点

1. 使用独立式的贾卡纱架, 提花能力更加强大;
2. 选用嵌入式舌针, 降低维护成本, 提高生产效率;
3. 配备电子横移和电子送经系统, 机器性能更加卓越;
4. 人机操作界面友好, 机器使用更加便捷。

Products Features

1. Using an independent jacquard creel, the pattern ability is more powerful;
2. Use individual latch needle to reduce maintenance costs and improve production efficiency;
3. Equipped with EL and electronic let-off systems, the machine performance is even more excellent;
4. The human-machine operation interface is friendly and the machine is more convenient to use.

技术参数

工作门幅/机号

138" E22/24

Working Width/Gauge

138" E22/24

梳栉数

5把地梳, 1把分离式贾卡梳
(RDJ7/1: 6把地梳, 1把分离式贾卡梳)

Bars Number

5 Ground Bars, and 1 separate piezo jacquard bar
(RDJ7/1: 6 Ground Bars, and 1 separate piezo jacquard bar)

脱圈板间距

2-8mm

Knock-over Distance

2-8mm

舌针类型舌

嵌入式舌针

Latch Needle Spec.

Individual Latch Needle

横移方式

电子横移

Pattern Drive

EL Drive

卷取方式

电子卷取

Batching Device

Electrical Batching

送经方式

EBC送经

Yarn Let-off

EBC

盘头配置

所有梳栉均使用Φ21" 或Φ30"

Beam Size

All Bars use Φ21" or Φ30"



Scan the QR code

应用图片 Applications



机器照片 Machine photos



安装示意图 Installation diagram

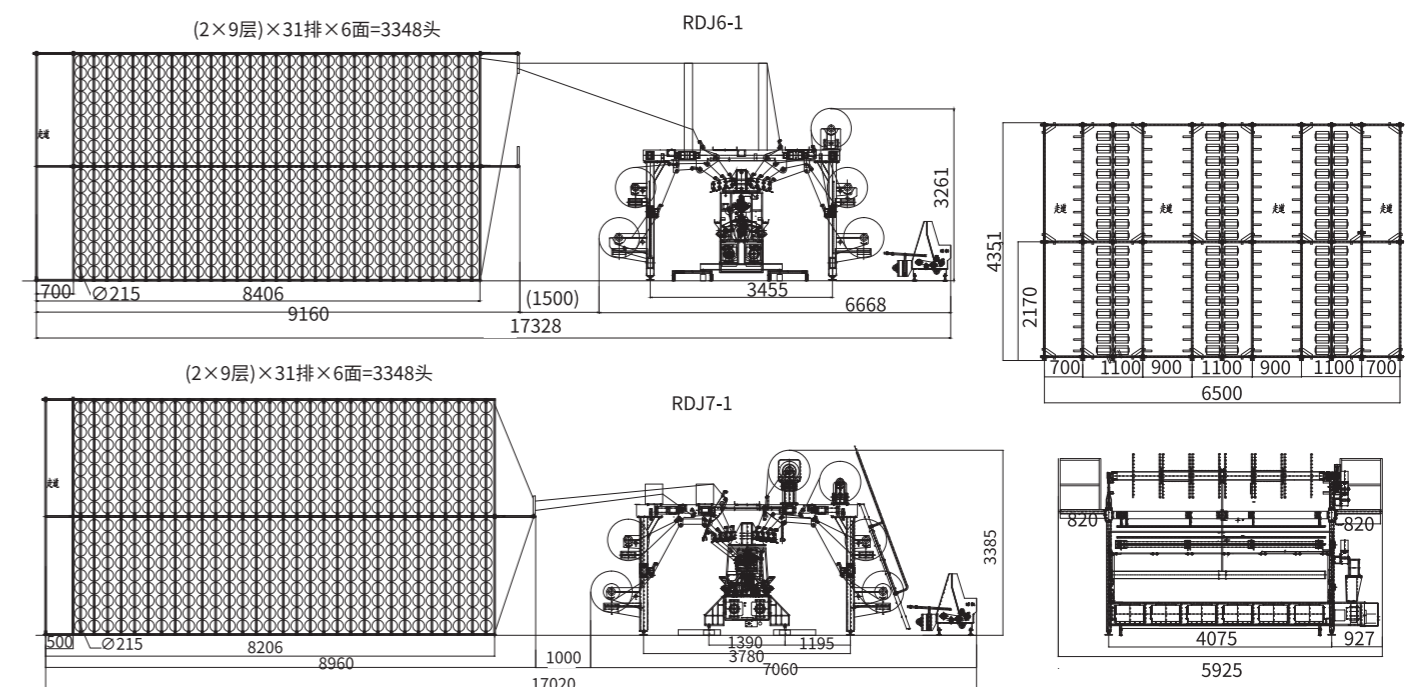

RDJ6/2是一款专门提花鞋面织物和无缝织物的高性能经编机。

RDJ6/2 is a high-performance warp knitting machine specializing in jacquard spacer shoe uppers fabrics and seamless fabrics.

机器特点

1. 双贾卡经编技术, 设计风格更加自由;
2. 可使用有弹和无弹纱线, 应用领域得以进一步延伸;
3. 选用嵌入式舌针, 降低维护成本, 提高生产效率;
4. 配备电子横移和电子送经系统, 机器性能更加卓越;
5. 人机操作界面友好, 机器使用更加便捷。

技术参数

工作门幅/机号

44" E22/24
138" E22/24

梳栉数

4把地梳, 2把分离式贾卡梳
(RDJ4/2: 2把地梳, 2把分离式贾卡梳)

脱圈板间距

0.85mm (无缝织物)
2-12mm (间隔织物)

舌针类型

嵌入式舌针

横移方式

电子横移

卷取方式

电子卷取

送经方式

EBC送经

盘头配置

所有梳栉均使用Φ21" 或Φ30"

Products Features

1. Using double jacquard technology, the pattern ability is more powerful;
2. Capable of using elastic and non-elastic yarn, textile applications expanded;
3. Use individual latch needle to reduce maintenance costs and improve production efficiency;
3. Equipped with EL and electronic let-off systems, the machine performance is even more excellent;
4. The human-machine operation interface is friendly and the machine is more convenient to use.

Technical Parameters

Working Width/Gauge

44" E22/24
138" E22/24

Bars Number

4 Ground Bars, and 2 separate piezo jacquard bar
(RDJ4/2: 2 Ground Bars, and 2 separate piezo jacquard bar)

Knock-over Distance

0.85mm (Seamless Fabric)
2-12mm (Spacer Fabric)

Latch Needle Spec.

Individual Latch Needle

Pattern Drive

EL Drive

Batching Device

Electrical Batching

Yarn Let-off

EBC

Beam Size

All Bars use Φ21" or Φ30"



Scan the QR code

应用图片 Applications



Seamless Pants



Seamless Dress



Jacquard Tape

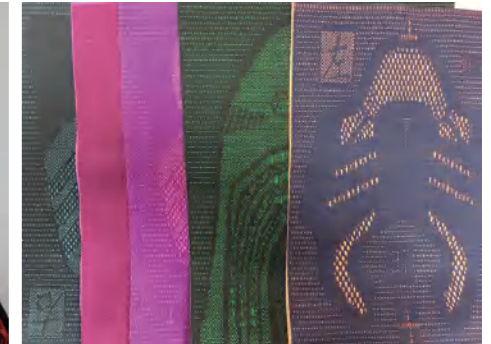

Sports Shoe Upper

机器照片 Machine photos



安装示意图 Installation diagram

